

Items Supplied >

- 1 - FRONT EXHAUST ASSEMBLY W / HEATSHIELD
- 1 - REAR EXHAUST ASSEMBLY W / HEATSHIELD
- 1 - EXHAUST BRACKET
- 4 - HOSE CLAMPS HS-24
- 2 - HOSE CLAMPS HS-28
- 4 - BOLT, HEX 5/16-18 x 5/8
- 2 - BOLT, HEX 3/8 x 1.0"
- 2 - SCREW, BUTTON ¼-20 x 3/8
- 1 - SCREW, S.H.C 3/8-16 x 2.50
- 1 - SCREW, S.H.C. ½-20 x 3.00
- 1 - SPACER, SHORT
- 1 - SPACER, LONG
- 2 - BILLET MUFFLER TIPS

Application(s) >

HARLEY:	
FXSTS	86-06
FLSTF	86-06
FXSTB	86-06
FXST	86-06
FXSTC	86-06
FXSTD	86-06
FLSTC	86-06

Instruction Manual >

6810

Page 1 of 2

PRIOR TO INSTALLATION, MAKE SURE YOUR STOCK HEADPIPE GASKETS ARE IN GOOD SHAPE. IF YOU HAVE ANY DOUBTS AS TO THEIR CONDITION, REPLACE THEM.

Read all instructions carefully and completely before installing your new exhaust system!

1. Remove stock exhaust system. On FLSTC, FLSTN, FLSTF, and FXSTS, remove the right floorboard. Next remove the two floorboard mounting bracket bolts leaving the third in place but loose and rotate mount down out of the way. (See Figure 1.) This will make installation of exhaust and heat shields possible.
2. On pre-2000 models, remove the stock lower mounting bar.
3. On models FLSTN, FLSTF, and FXSTD, remove the stock upper mounting bar.

If you have a 1999 model or older proceed to step #4.

If you have a 2000 model or newer proceed to step #5.

4. Remove the right passenger foot peg bolt. Position the motorcycle on the side stand with a floor jack under the swing arm pivot bolt on the right hand side. Raise the jack just enough to take the weight off the pivot bolt, remove the bolt and stock mounting bar. Reinstall the pivot bolt and torque it between 120-150 ft. lbs. Reinstall the passenger foot peg using the ½"-20 x 3" bolt and the supplied 1-5/8" long spacer.
5. Using a #50 Torx driver, remove the three mounting bolts, and set the mounting bar aside. (Two of the bolts are visible; removing the right hand passenger foot peg will allow access to the third bolt.) Replace the foot peg using the 3/8"-16 x 2-1/2" bolt and the supplied ¾" long spacer.
6. Bolts and spacer used in steps #4 and #5 may also be used on all Softail models to space the right rear foot peg away from the exhaust system if you so desire.
7. Remove the flange and retaining ring from the stock headpipes.
8. Place the exhaust mount bracket on the motorcycle and bolt into place using the supplied 3/8" bolts. (See Figure 2.)
9. Install the front and rear exhaust pipes on the motorcycle using supplied 5/16" bolts but **DO NOT TIGHTEN**. Make sure the pipes are parallel with each other.
10. Make sure the exhaust assembly is parallel to the ground, then tighten the following in order, muffler bracket to the motor, head pipe flanges to the motor (slowly tighten opposing nuts) and muffler assembly to the muffler bracket.

** Cobra recommends you always wear a helmet while riding. Please never operate your motorcycle while under the influence of alcohol and/or drugs. Enjoy the new look of your motorcycle and please ride safely.*

11. Unscrew the remaining hose clamps and feed the tail end of the clamp through the clips on the inside of the heat shields. The screw end of the hose clamp should be accessible for tightening but not visible when the heat shields are mounted to the pipes.
12. To install the front heatshield, first slide the rear portion of the heatshield over the muffler, continue to slowly slide it forward pushing the front of the shield gently into place between the frame and motor (Hint: Spread the hose clamps apart slightly to make it easier to slide them over the exhaust and head pipe area). Snug the heatshield clamps but **do not tighten**.
13. Install one billet tip on each heatshield. Fasten the tips with the supplied 1/4-20 screws making sure they snug up against the heatshield leaving no gap between the tip and heatshield when tightened. **If it is difficult to slide the tips into the heatshields loosen the clamps on the heatshield, failure to do this may cause damage to the chrome tips.**
14. Tighten the clamps on the heatshield.
15. Rotate the floorboard mount back into place and retighten bolts to factory specifications. Reinstall the right floorboard with its original hardware.
16. Make sure all the hardware (brackets, headpipes, heatshields, and tips) has been tightened appropriately and cleaned before starting your motorcycle.

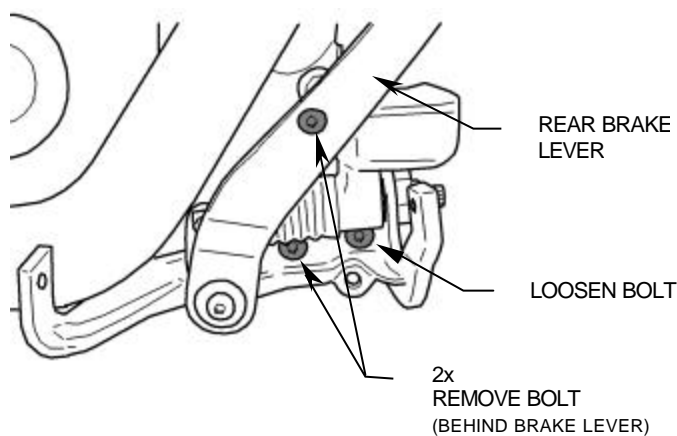

FIGURE 1

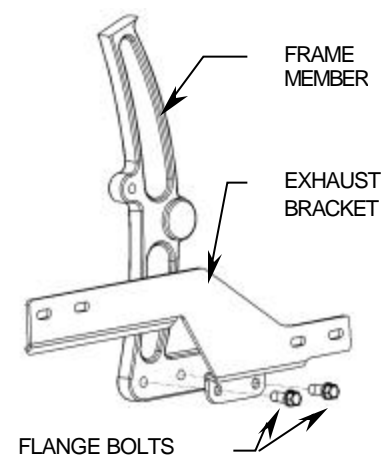

FIGURE 2

IMPORTANT: If your motorcycle is equipped with fuel injection it is recommended that you install a Cobra Fi2000 Digital Fuel Processor with your Cobra exhaust system. Fi2000 **Cobra Part #: 692-1605** for 2001 to 2005 Softail Models, and **Cobra Part#: 692-1604** for 2006 Softail Models. Cobra is not responsible for the performance of any other fuel management system used with Cobra exhaust systems.

Before starting your engine remove all fingerprints from chrome with a quality wax or chrome polish. Failure to do so can cause discoloration. Due to fluctuations in fuel injection/carburetion settings, timing, etc., Cobra Engineering does not warrant against chrome discoloration.