

Items Supplied >

- 1 – FRONT MUFFLER ASSEMBLY
- 1 – REAR MUFFLER ASSEMBLY
- 2 – CLAMP, 27-61MSC

Application(s) >

HARLEY:	
HERITAGE SOFTAIL	2006
HERITAGE SOFTAIL CLASSIC	00-06
SOFTAIL STANDARD	00-06
NIGHT TRAIN	00-06
SPRINGER SOFTAIL	00-06

Instruction Manual >

6054

Page 1 of 2

Read all instructions carefully and completely before installing your new slip-on mufflers

1. Unbolt the head pipe support clamp from the support bracket located midway down the rear head pipe and save the hardware for reinstallation.
2. Loosen all heat shield clamps for clearance but do not remove the heat shields.
3. Loosen both head pipes at the cylinders. Remove and save the mounting bolts that secure the mufflers to the mounting bracket/crossover tube.
4. Loosen the stock muffler clamps then rotate the head pipes/mufflers out until the crossover slips disengage. Remove the stock mufflers from the head pipes. The stock clamps will not be reused.
5. Remove gaskets from stock muffler crossover slips and install them into the supplied slip-on mufflers. If needed, replacement gaskets may be purchased through your dealer (HD Part #65927-00).
6. Position the supplied 27-61MSC clamps with hex head as shown in **Figure 1** and slide them onto the slip-on mufflers.
7. **NOTE: THE MUFFLER WITH THE COBRA LOGO WILL ALWAYS BE THE REAR MUFFLER.** Slide the mufflers onto the head pipes (reverse the order of removal) until the mounting holes align and crossover slips engage.
8. Fasten the mufflers using the stock mounting bolts in the same manner as stock but **do not tighten**.

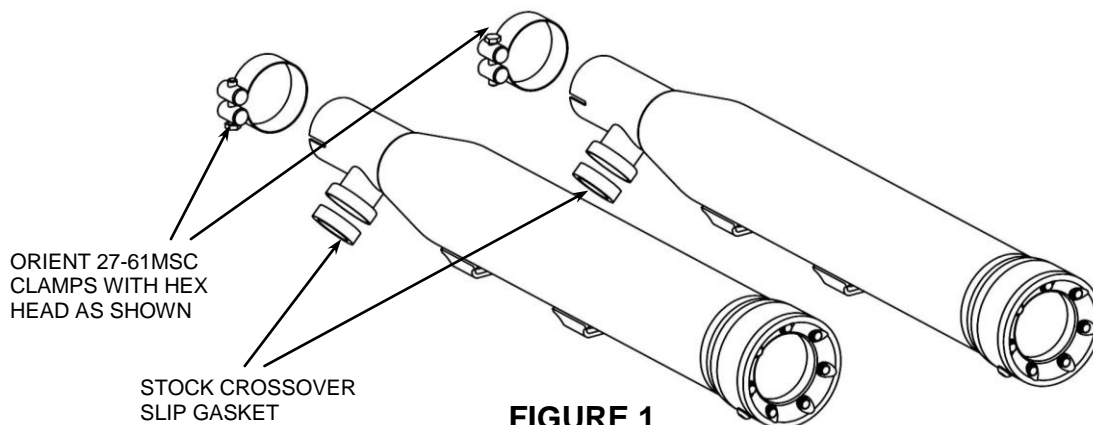

POSITION OF MUFFLERS AND MOUNTING BRACKETS SHOWN ABOVE MAY VARY FROM ACTUAL APPLICATION

Continued on Page 2

*** Cobra® recommends you always wear a helmet while riding. Please never operate your motorcycle while under the influence of alcohol and/or drugs. Enjoy the new look of your motorcycle and please ride safely.**

8. Check the alignment of the front and rear mufflers and make sure they are parallel. Check that the crossover slips remain engaged.
9. Tighten the mufflers to the mounting bracket.
10. Tighten the head pipe flange nuts to factory specifications.
11. Tighten the muffler clamps. (NOTE: The muffler clamps should be flush with the end of the muffler when tightened. **See Figure 2.** If the muffler clamps are slid past the slots on the slip collar the clamps will not tighten the mufflers properly).
12. Align the heat shields and tighten the heat shield clamps. Verify that the gap, where the mufflers meet stock heat shields, is similar to the gap the stock mufflers allotted.
13. Reinstall the head pipe support clamp and hardware. Tighten to factory specifications.
14. Tighten any remaining loose hardware to factory specifications.
15. **IMPORTANT:** Before starting your engine remove all fingerprints from chrome with a quality wax or chrome polish. Failure to do so can cause discoloration. Due to fluctuations in fuel delivery settings, timing, etc., Cobra Engineering does not warrant against chrome discoloration.

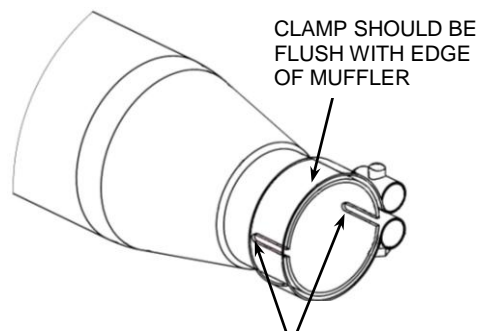

FIGURE 2 DO NOT SLIDE CLAMPS PAST SLOTS

REPLACEMENT E-GLASS PACKING AND OPTIONAL 1 $\frac{3}{4}$ " QUIET CORES MAY BE PURCHASED THROUGH YOUR DEALER OR ONLINE AT WWW.COBRAUSA.COM

IMPORTANT: To achieve optimum performance from your new mufflers it is suggested that you install a Cobra Fi2000® Digital Fuel Processor. Visit www.fi2000r.com

California does not allow the use of aftermarket exhaust systems that remove original equipment catalyts, (except for racing use only) unless the Air Resources Board has issued an Executive Order for that system.