

## Items Supplied >

- 1 – FRONT MUFFLER ASSEMBLY
- 1 – REAR MUFFLER ASSEMBLY
- 2 – CLAMP, 27-61MSC

## Application >

### HARLEY:

HERITAGE SOFTAIL CLASSIC	07-14
ROCKER	08-09
ROCKER C	08-11
BREAKOUT	13-14
SOFTAIL STANDARD	2007
NIGHT TRAIN	07-09
SOFTAIL CUSTOM	07-10

## Instruction Manual >

6053B

Page 1 of 1

### Read all instructions carefully and completely before installing your new slip-on mufflers

1. Remove the stock mufflers carefully and save the mounting bolts.
2. Position the supplied 27-61MSC clamps with hex head as shown in **Figure 1** and slide them onto the slip-on mufflers.
3. **NOTE: THE MUFFLER WITH THE COBRA LOGO WILL ALWAYS BE THE REAR MUFFLER.** Slide the mufflers onto the head pipes until the mounting holes align.
4. Fasten the mufflers using the stock mounting bolts in the same manner as stock but **do not tighten**. Verify that the gap, where the mufflers meet the stock heat shields, is similar to the gap the stock mufflers allotted.
5. Check all clearances and alignments then tighten the clamps. (**NOTE:** The muffler clamps should be flush with the end of the muffler when tightened. See **Figure 2**. If the muffler clamps are slid past the slots on the slip collar the clamps will not tighten the mufflers properly).
6. Tighten the mounting bolts to factory specifications.
7. **IMPORTANT:** Before starting your engine remove all fingerprints from all exhaust surfaces. To clean your black exhaust system use a liquid based soap detergent, such as dishwashing soap applied with a soft cloth and rinse with clean water. **Note:** Avoid abrasive cleaning methods such as granular or dry cleansers, simple green, scotch-brite or steel wool pads. Abrasives may breach the coating and shorten life.

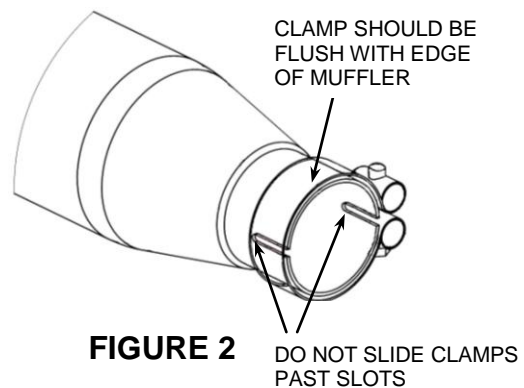
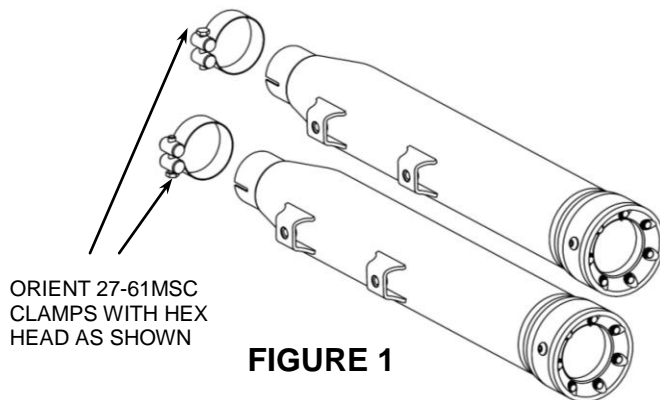

POSITION OF MUFFLERS AND MOUNTING BRACKETS SHOWN ABOVE MAY VARY FROM ACTUAL APPLICATION

**REPLACEMENT E-GLASS PACKING AND OPTIONAL 1 1/4" QUIET CORES MAY BE PURCHASED THROUGH YOUR DEALER OR ONLINE AT [WWW.COBRAUSA.COM](http://WWW.COBRAUSA.COM)**

**IMPORTANT:** To achieve optimum performance from your new mufflers it is suggested that you install a Cobra Fi2000® Digital Fuel Processor. Visit [www.fi2000r.com](http://www.fi2000r.com)

California does not allow the use of aftermarket exhaust systems that remove original equipment catalysts, (except for racing use only) unless the Air Resources Board has issued an Executive Order for that system.

**\* Cobra® recommends you always wear a helmet while riding. Please never operate your motorcycle while under the influence of alcohol and/or drugs. Enjoy the new look of your motorcycle and please ride safely.**