

Items Supplied >

- 1 – FRONT MUFFLER ASSEMBLY
- 1 – REAR MUFFLER ASSEMBLY
- 2 – CLAMP, 27-61MSC

Application(s) >

HARLEY:
SPORTSTER 883/1200

04-13

Instruction Manual >

6030

Page 1 of 2

Read all instructions carefully and completely before installing your new slip-on mufflers

1. Unbolt the headpipe support clamp from the support bracket located midway down the rear headpipe and save the hardware for reinstallation.
2. Loosen all heatshield clamps for clearance but do not remove the heatshields.
3. Loosen both headpipes at the cylinders. Remove and save the mounting bolts that secure the mufflers to the mounting bracket/crossover tube.
4. Loosen the stock mufflers clamps then rotate the headpipes/mufflers out until the crossover slips disengage. Remove the stock mufflers from the headpipes. The stock clamps will not be reused.
5. Remove gaskets from stock muffler crossover slips and install them into the supplied slip-on mufflers. If needed, replacement gaskets may be purchased through your dealer (HD Part #65927-00).
6. Slide the supplied 27-61MSC clamps over the slip-on mufflers and position them as shown in Figure 1.
7. **NOTE: THE MUFFLER WITH THE COBRA LOGO WILL ALWAYS BE THE REAR MUFFLER.** Slide the mufflers onto the headpipes (reverse the order of removal) until the mounting holes align and crossover slips engage. Fasten the mufflers using the stock mounting bolts in the same manner as stock but **do not tighten**.

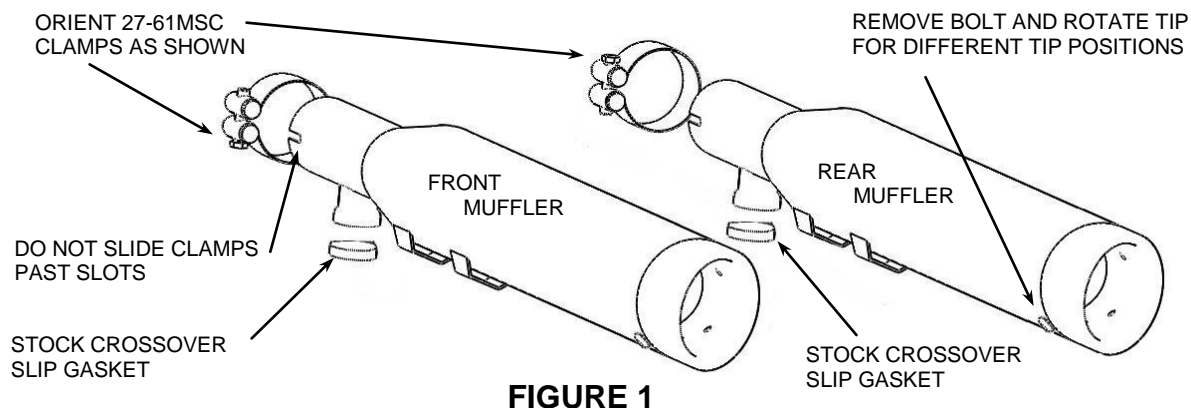

Continued on Page 2

* **Cobra® recommends you always wear a helmet while riding. Please never operate your motorcycle while under the influence of alcohol and/or drugs. Enjoy the new look of your motorcycle and please ride safely.**

8. Check alignment of front and rear mufflers and make sure they are parallel and crossover slips remain engaged. Tighten mufflers to mounting bracket. Tighten headpipe flange nuts. Tighten muffler clamps. (NOTE: If the muffler clamps are slid past the slots on the slip collar the clamps will not tighten the mufflers properly).
9. Align heatshields and tighten heatshield clamps. Verify that the gap, where the mufflers meet stock heatshields, is similar to the gap the stock mufflers allotted.
10. Reinstall headpipe support clamp and hardware. Tighten to factory specifications.
11. Tighten any remaining loose hardware to factory specifications.
12. NOTE: The exhaust tips may be loosened and oriented to various positions for different visual effects.

REPLACEMENT E-GLASS PACKING AND OPTIONAL 1 $\frac{3}{4}$ " QUIET CORES MAY BE PURCHASED THROUGH YOUR DEALER OR ONLINE AT WWW.COBRAUSA.COM

IMPORTANT: To achieve optimum performance from your new mufflers it is suggested that you install a Cobra Fi2000® Digital Fuel Processor. Visit www.fi2000r.com

Before starting your engine remove all fingerprints from chrome with a quality wax or chrome polish. Failure to do so can cause chrome discoloration.

California does not allow the use of aftermarket exhaust systems that remove original equipment catalyists, (except for racing use only) unless the Air Resources Board has issued an Executive Order for that system.