

## Items Supplied >

- 1 – MUFFLER ASSEMBLY
- 1 – CHROME MUFFLER SLIP HEATSHIELD
- 1 – HS-32 HOSE CLAMP

**NOTE:** THE MUFFLER INLET GASKET CANNOT BE REUSED. A NEW GASKET (HD PN# 65900040) MUST BE PURCHASED BEFORE INSTALLATION.

## Application >

HARLEY SOFTAIL:  
FLSB SPORT GLIDE 18-19

**NOTE:** THIS IS A SINGLE MUFFLER SLIP-ON.

## Instruction Manual >

6520B

Page 1 of 2

**\*\*\*NOTE: THE MUFFLER INLET GASKET CANNOT BE REUSED. A NEW GASKET (HD PN# 65900040) MUST BE PURCHASED BEFORE INSTALLATION.\*\*\***

**Read all instructions carefully and completely before installing your new slip-on muffler.**

1. Remove the stock muffler. Loosen the muffler clamp and remove the two bolts on the muffler mount. Be careful not to strip the allen head bolts when loosening the bolts.
2. To remove the muffler, first rotate the muffler counter clockwise a small amount until the mounting brackets on the muffler move away from the muffler mount attached to the frame and then slide the muffler backward off of the headpipe. Be sure the hex head of the muffler clamp does not contact the muffler bracket as it is being slid off so that it does not scratch the mount. Save the muffler clamp and the bolts as they will be reused.
3. Position the stock clamp with hex head as shown in **Figure 1** and slide it onto the new muffler slip.
4. Install a new muffler inlet gasket into the muffler inlet. See **Figure 1**. **NOTE: THE MUFFLER INLET GASKET CANNOT BE REUSED. A NEW GASKET (HD PN# 65900040) MUST BE PURCHASED BEFORE INSTALLATION.**

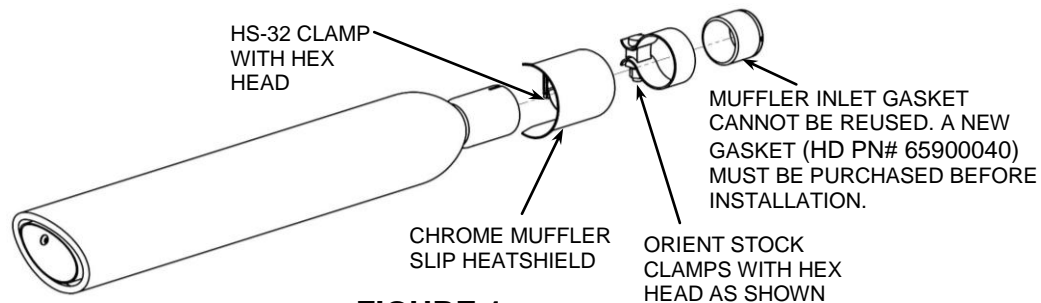

**FIGURE 1**

5. Unscrew the supplied HS-32 hose clamp and insert it through the clip on the muffler slip heatshield so that the hex head is on the inside and facing down. See **Figure 1**.
6. Very carefully install the heatshield onto the muffler slip so that the larger flaired end is facing the dome of the muffler body and the smaller domed end of the heatshield is facing forward. See **Figure 1 & 2**. Be careful not to scratch the muffler dome or the heatshield. The hose clamp will go between the muffler dome and the stock muffler clamp.
7. Align the heatshield so there is a small gap between the muffler dome and the large flaired end of the heatshield and then snug the hose clamp but **DO NOT TIGHTEN** at this time. See **Figure 2**.
8. Slide the muffler onto the head pipe until the mounting holes align and fasten the muffler using the stock bolts in the same manner as stock but **DO NOT TIGHTEN** at this time. See **Figure 2**.

Continued on Page 2

**DISCLAIMER: NOT LEGAL FOR SALE OR USE IN CALIFORNIA ON ANY POLLUTION CONTROLLED MOTOR VEHICLES.**

9. Align the muffler slip heatshield so there is a small gap between the muffler slip heatshield and the muffler dome and between the muffler slip heatshield and the stock headpipe heatshield. Also be sure to rotate the muffler slip heatshield so the top edge of the muffler slip heatshield aligns with the top edge of the stock headpipe heatshield. Adjust the muffler forward or backward to decrease or increase the gaps between the heatshields. NOTE: It may be necessary to slide the rear stock headpipe heatshield fore or aft by loosening the hose clamps in order for all three parts to align properly.
10. Once everything is aligned properly tighten the muffler clamp. (NOTE: The muffler clamp should be flush with the end of the muffler when tightened. See **Figure 3**. If the muffler clamp is slid backward past the slots on the muffler slip the clamp will not tighten the muffler properly which may cause an air leak and possible discoloring of the muffler body).
11. Tighten the mounting bolts to factory specifications.
12. Check that the muffler slip heatshield and stock headpipe heatshield are still aligned properly and tighten the hose clamp on the muffler slip heatshield and the stock heatshields if necessary.
13. **IMPORTANT: Before starting your engine remove all fingerprints from all exhaust surfaces. To clean your black exhaust system use a liquid based soap detergent, such as dishwashing soap applied with a soft cloth and rinse with clean water. Note: Avoid abrasive cleaning methods such as granular or dry cleansers, simple green, scotch-brite or steel wool pads. Abrasives may breach the coating and shorten life.**

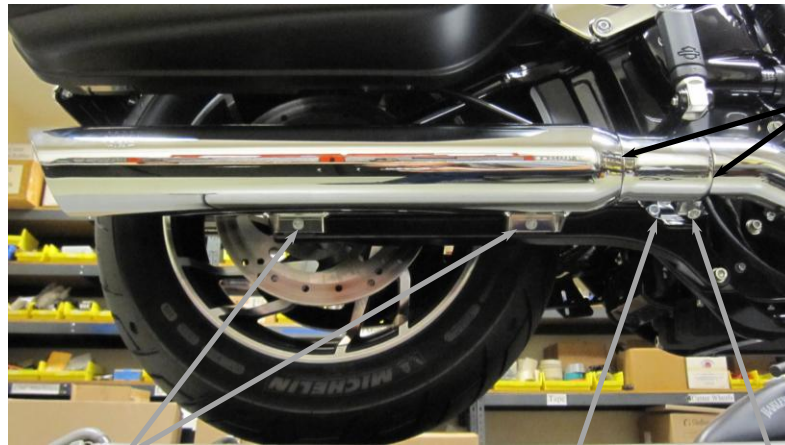

STOCK MOUNTING BOLTS

**FIGURE 2**

HS-32 HOSE CLAMP

STOCK MUFFLER CLAMP

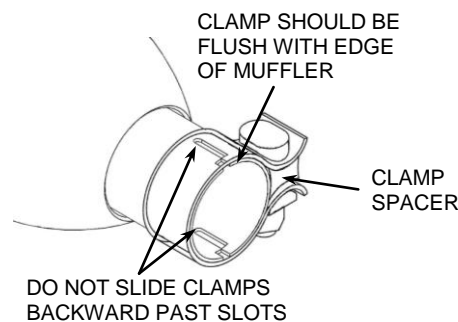

**FIGURE 3**

**DO NOT REMOVE BAFFLE FROM MUFFLER BODY.  
REMOVING BAFFLE WILL VOID WARRANTY.**

**IMPORTANT:** To achieve optimum performance from your new mufflers it is suggested that you install a Cobra Fi2000® Digital Fuel Processor.

**DISCLAIMER: NOT LEGAL FOR SALE OR USE IN CALIFORNIA ON ANY POLLUTION CONTROLLED MOTOR VEHICLES.**