

Items Supplied >

1 – FRONT EXHAUST HEADPIPE W/ HEATSHIELD
1 – REAR EXHAUST HEADPIPE W/ HEATSHIELD
1 – EXHAUST MOUNT BRACKET
1 – EXHAUST MUFFLER
4 – CLAMPS, HS-24
2 – CLAMPS, HS-28
2 – CLAMPS, 27-61 MSC
2 – BOLT, HEX 5/16-18 x 5/8"
2 – BOLT, ALLEN M8 x 20mm
1 – FOOTPEG RELOCATION MOUNT

Application(s) >

KAWASAKI VN900

06-19

Instruction Manual >

4218

Page 1 of 2

PRIOR TO INSTALLATION, MAKE SURE YOUR STOCK HEADPIPE GASKETS ARE IN GOOD SHAPE. IF YOU HAVE ANY DOUBTS AS TO THEIR CONDITION, REPLACE THEM.

Read all instructions carefully and completely before installing your new exhaust system

1. Remove stock exhaust system and remove stock upper and lower exhaust mounts on the right side frame rail, retain 2 flange bolts from stock upper bracket for later reinstallation. The two stock exhaust brackets will not be used with the Cobra Exhaust System.
2. Loosen and move the right side floorboard assembly out of the way to ease installation of the exhaust, but **DO NOT REMOVE**.
3. Remove stock right side passenger footpeg/floorboard and replace with footpeg relocation mount using the supplied M8 allen bolts. See Figure 1. Using the stock footpeg hardware mount stock footpeg to footpeg relocation mount.
4. Remove the exhaust mount bracket from the box and mount it to the motorcycle frame using the stock bolts retained in Step 1, but **DO NOT TIGHTEN** at this time, see Figure 1.
5. Install the front and rear head pipes onto the motorcycle using the supplied Cobra flanges and stock acorn nuts. Make sure the pipes are parallel to each other. **DO NOT TIGHTEN**.
6. Remove the muffler assembly from the box and slide two supplied 27 - 61MSC clamps onto the muffler tubes. The clamps should be orientated as shown in Figure 1. Slide the muffler onto the head pipes by tapping it onto the head pipes with your hand as you push the mufflers forward making sure the muffler slides as far forward as possible. Secure the muffler assembly to the exhaust mount bracket using the supplied 5/16 hex bolts but **DO NOT TIGHTEN**.
7. Make sure the muffler assembly is parallel to the headpipes (this is critical) then tighten the following in order; exhaust mount to the frame, muffler assembly to the exhaust mount, head pipe flanges to the motor (slowly tighten opposing acorn nut) and muffler clamps. (NOTE: If the muffler clamps are slid to far up the muffler or past the two slots, the clamps will not tighten.)
8. On the front and rear heatshields, unscrew the remaining hose clamps and feed the tail end of the clamp through the clips on the inside. The screw end of the hose clamps should be accessible for tightening but not visible when the heatshields are mounted to the pipes.

*** Cobra® recommends you always wear a helmet while riding. Please never operate your motorcycle while under the influence of alcohol and/or drugs. Enjoy the new look of your motorcycle and please ride safely.**

9. To install the front heatshield, first slide the rear portion of the heatshield over the muffler, continue to slowly slide it forward pushing the front of the shield gently into place between the frame and motor (Hint: Spread the hose clamps apart slightly to make it easier to slide them over the muffler assembly and head pipes). Snug the heatshield clamps but **DO NOT TIGHTEN**.
10. Install the rear heatshield in the same manner as the front heatshield.
11. Tighten the clamps on the heatshields.
12. Reinstall the right side floorboard assembly; tighten the bolts to factory specifications.
13. Make sure all the hardware (brackets, headpipes, heatshields, and baffles) have been tightened and cleaned before starting the motorcycle.

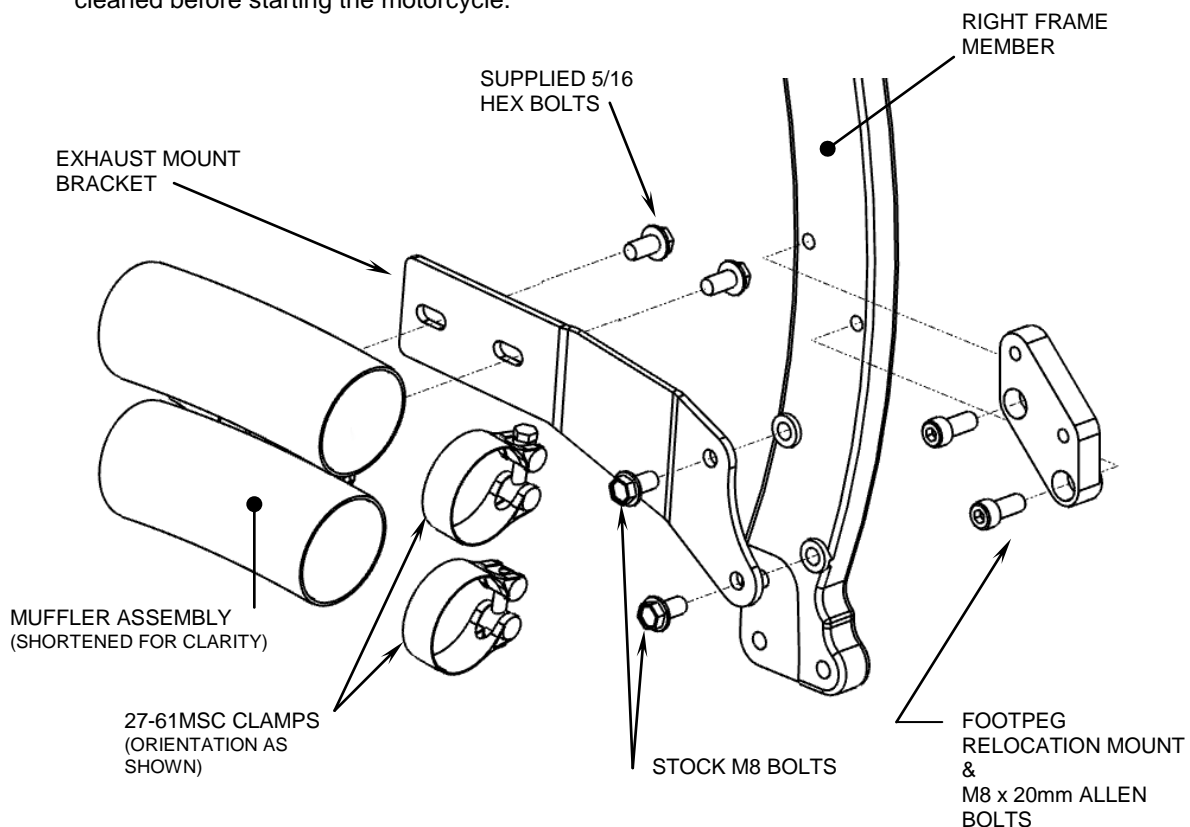

FIGURE 1

IMPORTANT: Cobra highly recommends using a Fi2000® Fuel Management System to help eliminate lean conditions and popping sounds. (Cobra Part# 92-1968 for 49 state models and Part# 92-1968-50 for CA models.)

Before starting your engine remove all fingerprints from chrome with a quality wax or chrome polish. Failure to do so can cause discoloration. Due to fluctuations in fuel injection/carburetion settings, timing, etc., Cobra Engineering does not warrant against chrome discoloration.

California does not allow the use of aftermarket exhaust systems that remove original equipment catalyts, (except for racing use only) unless the Air Resources Board has issued an Executive Order for that system.