

Items Supplied >

1 – FRONT HEADPIPE
1 – FRONT HEATSHIELD
1 – REAR MUFFLER ASSEMBLY
1 – REAR HEATSHIELD
1 – EXHAUST MOUNT BRACKET
4 – CLAMP, HS-24 HOSE (SMALLER)
2 – CLAMP, HS-28 HOSE (LARGER)
1 – CLAMP, 27-61 MSC
2 – BOLT, 5/16"-18 x 5/8" HEX FLANGE W/ LOCKPATCH
2 – BOLT, 3/8"-16 X 1 1/4" LOW HEAD ALLEN
1 – BRACKET, PASSENGER FLOORBOARD RELOCATION, RIGHT
1 – BRACKET, PASSENGER FLOORBOARD RELOCATION, LEFT
1 – SPACER PLATE, RIDER FLOORBOARD

Application(s) >

HARLEY:
TOURING MODELS 2010-2013

Instruction Manual >

6230

Page 1 of 4

PRIOR TO INSTALLATION, MAKE SURE THE STOCK HEADPIPE GASKETS ARE IN GOOD CONDITION, IF THERE IS ANY DOUBTS ABOUT THEIR CONDITION REPLACE THEM.
Read all instructions carefully and completely before installing your new exhaust system.

1. Remove both left and right saddlebags and set aside.
2. If motorcycle comes equipped with passenger floorboards (not footpegs) remove them both from left and right side of the frame and set aside.
3. Now remove the right side rider floorboard from the floorboard mounts and set aside. Remove the right rear floorboard mount from frame and set aside. See Figure 5 for reference.
4. Remove the right side electrical cover to expose the (2) O₂ sensors connectors. Disconnect the connectors for the front and rear headpipes from the motorcycle wire harness. NOTE: The O₂ sensor with the black connector threads into rear headpipe bung, while the O₂ sensor with the light grey connector threads into front headpipe bung.
5. Remove the stock exhaust system. Remove and save the stock flanges, flange nuts, retaining rings and O₂ sensors from the stock headpipes. Make sure to remove the stock muffler mount sliders and the rubber mounts from the saddlebag support structure.
6. Remove the stock crossover headpipe hanger bracket by removing the (2) stock allen bolts located on the backside of the transmission pan underneath the motorcycle. See Figure 1.
7. Remove the stock front headpipe support bracket (and pipe clamp) from the transmission case and install the supplied exhaust mount in this location using the stock bolts, but **DO NOT TIGHTEN**. See Figure 2.
8. Install the stock exhaust flanges, retaining rings and O₂ sensors on the supplied front and rear headpipes.
9. Install the front headpipe onto the front cylinder using two stock nuts from Step 5 but **DO NOT TIGHTEN**.
10. Place the supplied 27-61msc clamp onto the lower muffler inlet then slide the rear headpipe / muffler assembly onto the front headpipe and into the rear exhaust port. Bolt rear headpipe onto the rear cylinder using the stock nuts from Step 5 but **DO NOT TIGHTEN**. See Figure 3 for clamp orientation.
11. Bolt the muffler assembly to the exhaust mount using the supplied 5/16" bolts. **DO NOT TIGHTEN**.
12. Make sure the front headpipe is inserted properly into the rear assembly. Tighten the following in order; exhaust mount to the transmission case, then the flange nuts securing the exhaust flanges (slowly tighten opposing nuts), followed by the muffler to the exhaust mount. Tighten the 27-61msc clamp last. (NOTE: If the muffler clamp is slid past the slots on the muffler inlet the clamp will not tighten properly). See Figure 3.

* **Cobra® recommends you always wear a helmet while riding. Please never operate your motorcycle while under the influence of alcohol and/or drugs. Enjoy the new look of your motorcycle and please ride safely.**

13. Remove heatshields and hose clamps from packaging. Unscrew the hose clamps and feed the tail end of the clamps through the clips on the inside of the heatshield; the larger clamps go to the rear of the heatshields where they will rest on the muffler bodies, smaller ones to the front for the headpipes. The screw end of the hose clamp should be accessible for tightening but not visible when heatshields are mounted to the pipes. See Figure 4 for clamp orientation.
14. To install the front heatshield, first slide the rear portion of the heatshield over the muffler, continue to slowly slide it forward pushing the front of the shield gently into place between the frame and motor (Hint: Spread the hose clamps apart slightly to make it easier to slide them over the muffler assembly and headpipes). Make sure the muffler clamp doesn't interfere with the heatshields and is aligned as shown in Figure 3. Snug the heatshield clamps but **DO NOT TIGHTEN**.
15. Install the rear heatshield in the same manner as the front heatshield. Make sure heatshields are properly aligned with headpipes then tighten all hose clamps.
16. Reconnect the O₂ sensors back into the wire harness. Make sure to match corresponding male and female connectors of the same color. Refer to Step 4.
17. Insert the supplied floorboard spacer plate between the rear floorboard mount and the frame, then align the dowel pin and reinstall the allen bolt, tightening to factory specifications. See Figure 5.
18. Reinstall the right side floorboard and tighten all bolts to factory specifications.
19. If the passenger floorboards were removed in Step 2, install the supplied right side passenger floorboard relocation bracket to the top holes of stock passenger floorboard location using the supplied 3/8"-16 low head allen bolt and alignment pin. Then install the stock floorboard mount to top holes in the relocation bracket using the stock hardware as shown in Figure 6.
20. Repeat Step 19 for passenger floorboard relocation on left side if desired.
21. Reinstall the saddlebags and any other previously removed items. Tighten to factory specifications.
22. Make sure all the hardware (brackets, headpipes, heatshields, mufflers and floorboards) have been tightened appropriately and all finger prints cleaned off before starting your motorcycle.

IMPORTANT: If your motorcycle is equipped with fuel injection it is recommended that you install a Cobra Fi2000[®] PowrPro Tuner with your Cobra exhaust system, Cobra Part#: **692-1615AT** for 2010-2012; or **692-1615CL-50** for California models 2010-2012).

Before starting your engine remove all fingerprints from chrome with a quality wax or chrome polish. Failure to do so can cause discoloration.

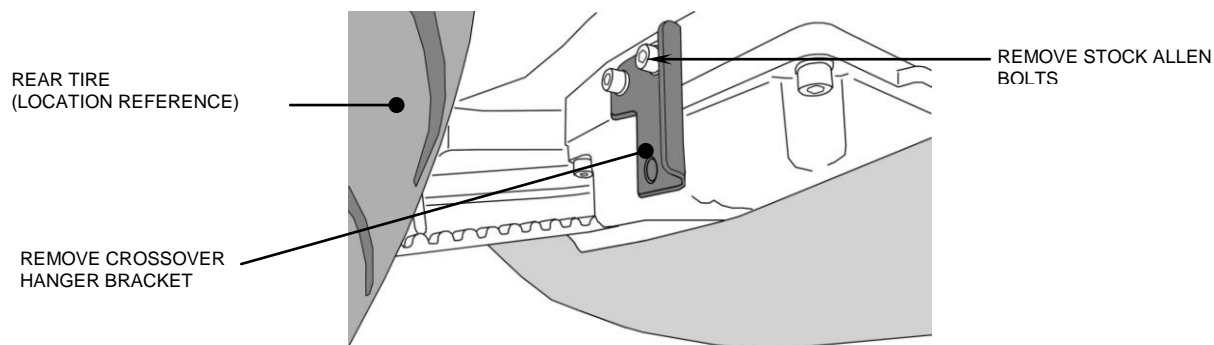

FIGURE 1

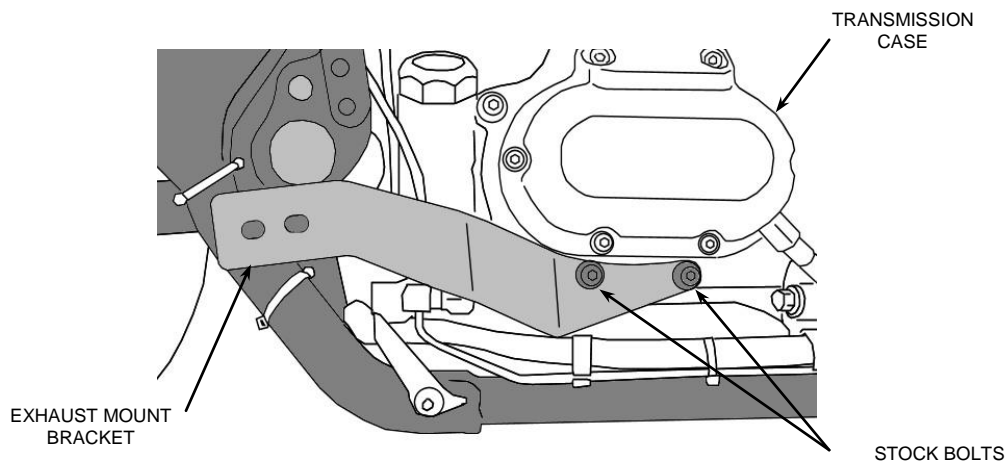

FIGURE 2

SLOTS MUST BE VISIBLE TO CLAMP PROPERLY

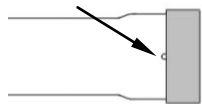
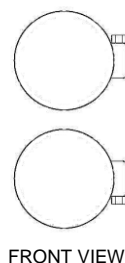
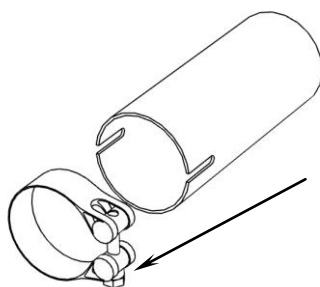

FIGURE 3



ORIENTATE CLAMPS AS SHOWN

FIGURE 4

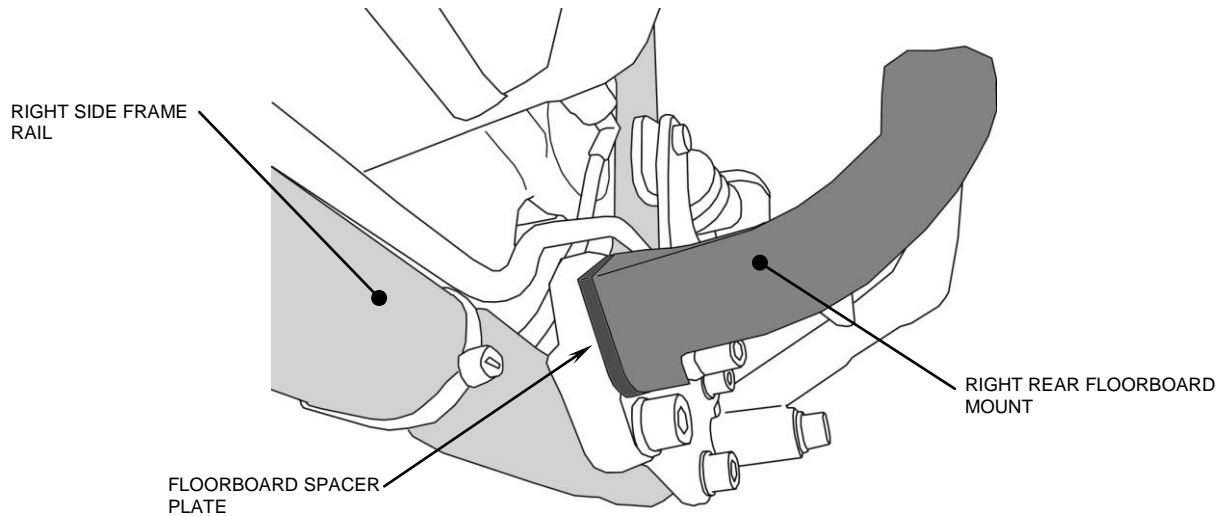

FIGURE 5

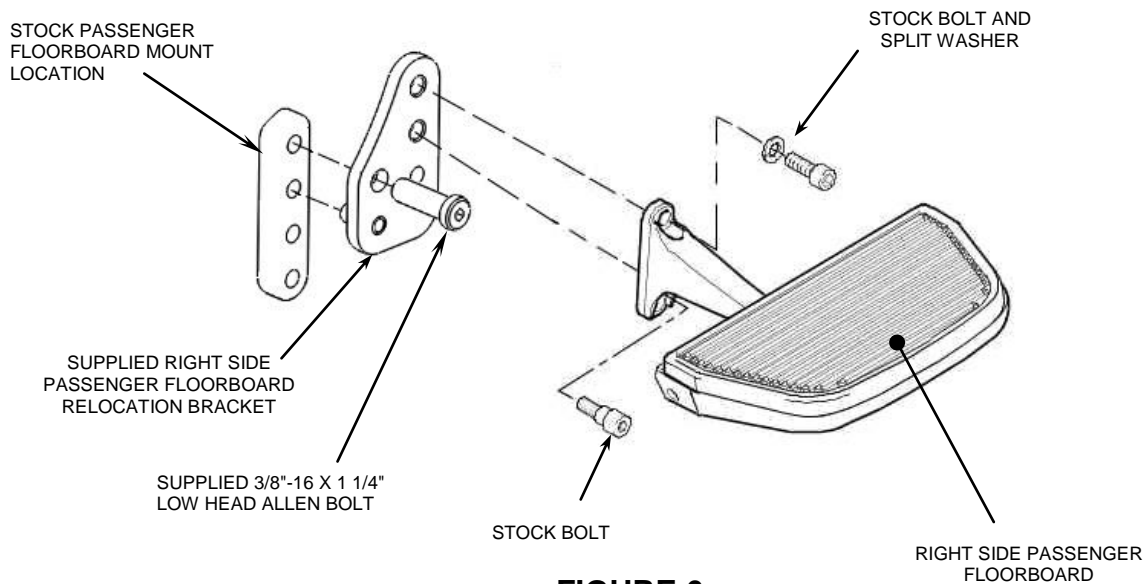

FIGURE 6

California does not allow the use of aftermarket exhaust systems that remove original equipment catalyts, (except for racing use only) unless the Air Resources Board has issued an Executive Order for that system.